

MegaCAD USF Sheet metal package

More efficient sheet metal processing.

Use MegaCAD USF sheet metal package to ensure a fast and reliable manufacturing process – from the design of the metal structure through the automatic unfolding process to the manufacturing drawing. Powerful functions and well-thought-out design tools are combined under an intuitive user interface.

The software is the result of extensive knowledge of the material and practical experience of sheet metal processing. The flexible and accessible design options allow you to create within a very short time every conceivable form of container, pipe, chemical apparatus and heating and climate components. Technical requirements of the production process are identified during the design phase and solutions automatically offered.

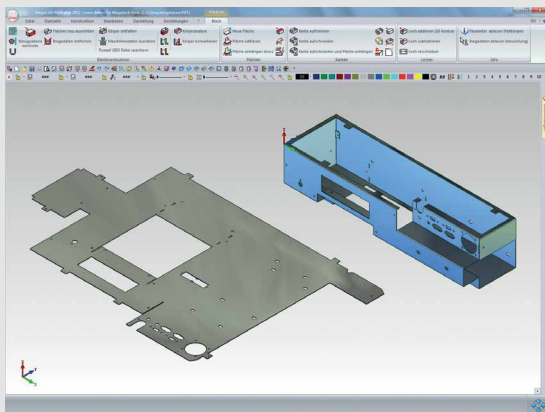

The benefits at a glance:

- ▷ 3D modeler and full-feature 2D drawing board in one
- ▷ Flexible accessible design with no need to lose time searching for the appropriate non-standard item
- ▷ Smooth data exchange through 2D and 3D interfaces
- ▷ Generate defined standard parts by entering a few parameters
- ▷ Automatic detection of incorrect notching and incongruities
- ▷ German software: developers and service close at hand
- ▷ Easy to work with, from design to production

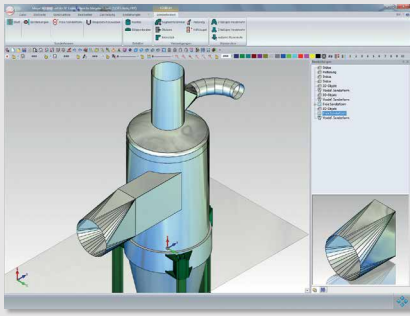

Predefined special shapes for container and pipe construction

- ▷ Specify dimensions directly on the component
- ▷ Automatic recognition of connection type
- ▷ Input screens for pipe / cylinder jacket, lobster-back bend, elbows
- ▷ Flanged and dished heads (optionally with segmentation)
- ▷ Y-branch pipe, two and multiple connecting pieces

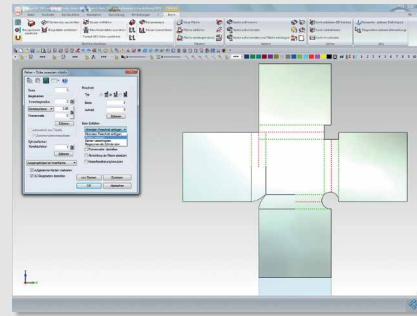

Automatic processing with various options

- ▷ minimum cutout
- ▷ insert radii
- ▷ trim edges
- ▷ handle bending zones as a cylinder

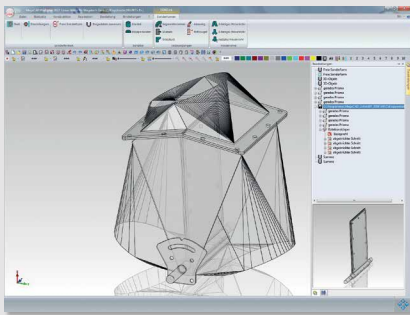

Flexible non-standard shapes

- ▷ Connect any cross-sections
- ▷ Any cross section can be selected from the design
- ▷ Approximation with triangles or flat squares

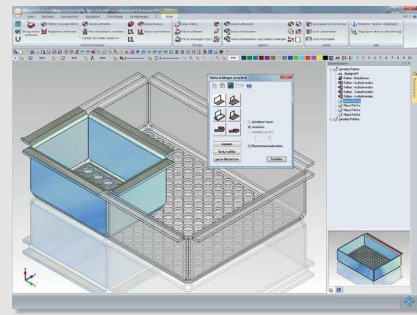

Edit surfaces

- ▷ Subsequent modification of metal thickness and bend edges
- ▷ Separate edges
- ▷ Modify lugs

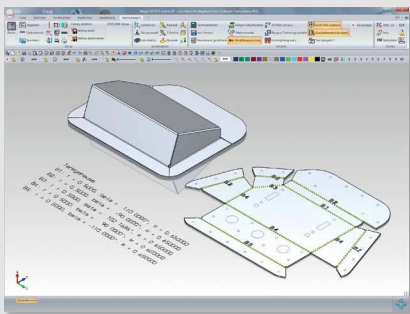

Fabrication drawings for sheet metal parts

- ▷ Comments and bending tables
- ▷ Bending directions and drawing styles are variable

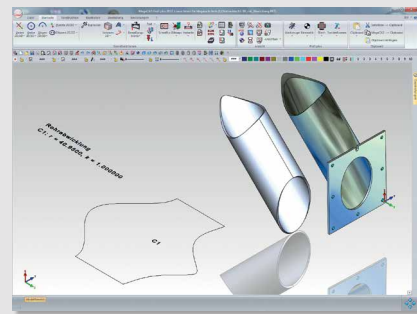

Adoption of thin-walled 3D models (including imported data)

- ▷ Conversion of thin-walled 3D models into parametric sheet metal parts
- ▷ Variable wall thickness / bending radii

We look forward to your call:

Megatech Software GmbH
Große Elbstr. 43
22767 Hamburg
Tel. +49 (0)40 507973-0
Fax +49 (0)40 507973-20
hamburg@megatech.de

Megatech Software GmbH
Kaistr. 18
40221 Düsseldorf
Tel. +49 (0)211 220516-0
Fax +49 (0)211 220516-20
duesseldorf@megatech.de

Megatech Software GmbH
Kantstr. 112-114
10627 Berlin
Tel. +49 (0)30 315958-0
Fax +49 (0)30 3132411
berlin@megatech.de

4CAM GmbH
Hauptstr. 18
86756 Reimlingen
Tel. +49 (0)9081 805067-0
Fax +49 (0)9081 805067-67
info@4cam.de

www.megacad.de

MegaCAD-Zentrum Kretzler
Siechenöschle 7
73312 Geislingen
Tel. +49 (0)7331 9537-0
Fax +49 (0)7331 9537-11
kretzler@kretzler.de